

Dear Customer

Congratulations! You have purchased a pool of superior quality and durability. To achieve the best possible results, follow the instructions carefully. Failure to follow the installation procedures may result in damage to your pool or property and void your warranty. We recommend that you make a preliminary study of the instructions booklet to familiarize yourself with the different parts of your pool. Make sure that you understand each step thoroughly before you begin assembling.

We wish you a most pleasant and refreshing summer.

WARNING: Be sure you have read and understood the "Safety Information" sheets before you begin your pool installation.



WARNING: For your safety, your pool is not designed for diving and/or jumping head first. Please do not dive. Diving may result in permanent injury or death.

1 SITE PREPARATION

When selecting a site for your pool, take into account city by-laws regarding fences and utilities laws pertaining to electrical cables, as well as the landscaping which you are planning once the pool is installed.

Drive a stake into the ground at the center of the site. Using a measuring tape, draw a circle 15 cm to 20 cm (6" to 8") longer in radius than the pool, depending on the width of the uprights (See Illustration 1.1).

Remove all grass from the area which you have just outlined.

Make sure to order the required quantity of sand and stone dust (See Chart).

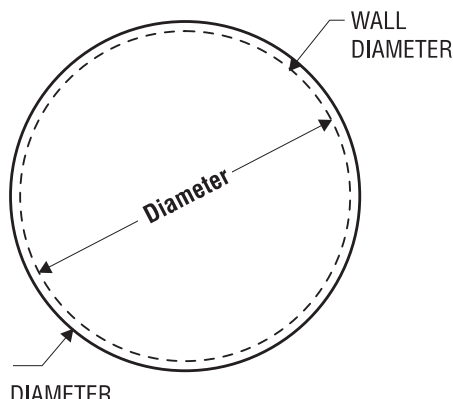
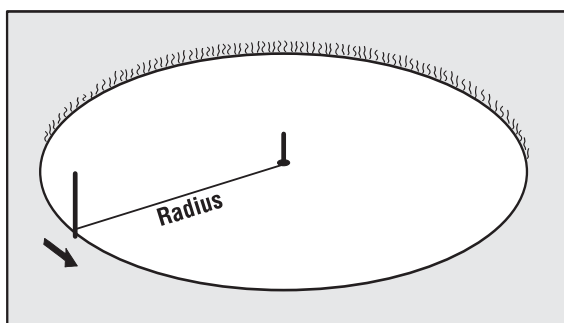

Illustration 1.1



Chart

WALL DIAMETER	TURF REMOVAL DIAMETER		NECESSARY MATERIALS *	
	RADIUS	DIAMETER	SAND	STONE DUST
3.66 m (12')	2.03 m (6' 8")	4.06 m (13' 4")	1 Ton	1/3 Ton
4.57 m (15')	2.50 m (8' 2")	5.00 m (16' 4")	1 1/4 Ton	1/2 Ton
5.48 m (18')	2.95 m (9' 8")	5.90 m (19' 4")	1 1/2 Ton	3/4 Ton
6.40 m (21')	3.40 m (11' 2")	6.80 m (22' 4")	1 3/4 Ton	1 Ton
7.31 m (24')	3.85 m (12' 8")	7.70 m (25' 4")	2 Tons	1 1/2 Ton
8.22 m (27')	4.30 m (14' 2")	8.60 m (28' 4")	2 1/4 Tons	1 3/4 Ton
9.14 m (30')	4.57 m (15' 8")	9.14 m (31' 4")	2 1/2 Tons	2 Tons

* If you use only sand, add stone dust tonnage to sand.

2 SITE LEVELLING

Level the edge of the circle, from the turf removal line up to 30 cm (12") within the circle.

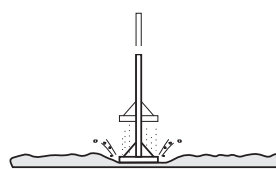
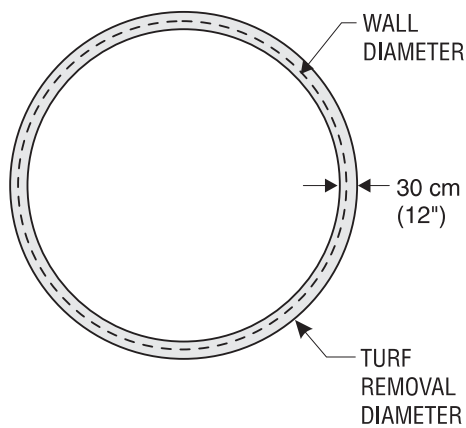

Illustration 2.1

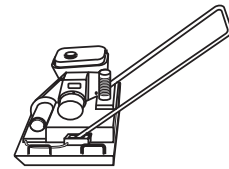

Illustration 2.2

Optional

The center of the circle can then be excavated at the desired depth, not to exceed 15 cm (6") for a standard liner (See Illustration 2.3).

Remove any stone, pieces of wood or other debris from within the circle. Flatten any protrusion and pack the soil tightly. Spread the area with salt to prevent roots from growing back and to eliminate earthworms. Spread also ant repellent; all causes of post-installation cracking.

To protect the liner, cover with a think 2 cm (3/4") layer of compacting sand.

Make sure you add a sufficient quantity of sand to the base finishing inside the circle (See Step 6).

It is possible to install the pool on a concrete (dalle) and to use a (tapis de sol).

To do this, use a carpenter's level set on a large straight beam, a rope or an optical level.

Carefully pack the soil using a tampering tool or vibrating plate (See Illustrations 2.1 and 2.2), especially those areas where a large quantity of soil was added.

It is also highly recommended to firm up the edge by adding a 2 cm (3/4") layer of stone dust (or sand).

Illustration 2.3

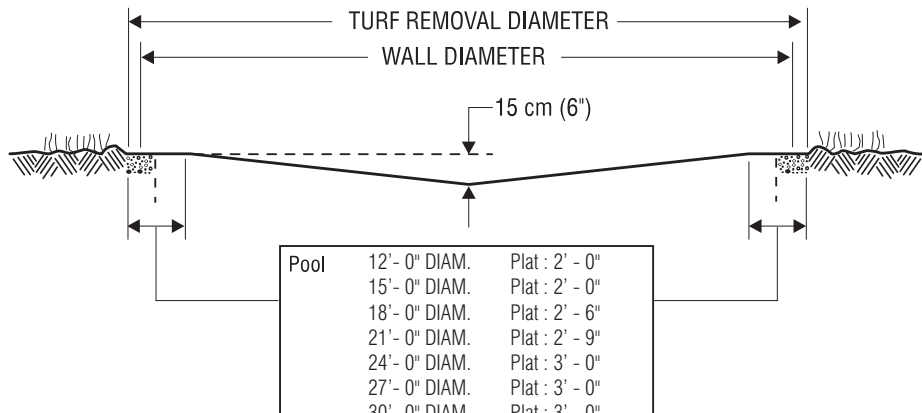

3

BOTTOM DRAIN ASSEMBLY (if applicable)

Dig a hole 30 cm (12") wide by approximately 25 cm (10") deep in the center of the circumference.

From the center hole to the projected location of the pool motor, dig a 15 cm (6") wide trench. Place the removed soil aside to be used later to cover the hose.

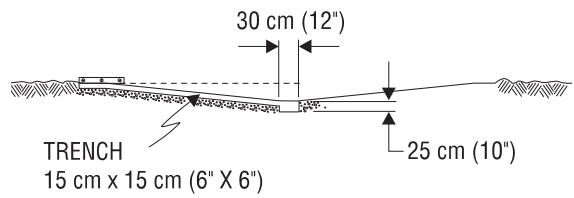

Bottom Drain Assembly

Place teflon around the threaded plug. Screw in drain holes using large pliers. Glue the connector in the appropriate opening.

Take one of the two rubber rings and adjust it to the top of the drain, aligning the holes carefully. Secure with strips of adhesive tape to prevent sand from penetrating inside the holes once the drain has been installed.

Secure one end of the long black or white hose inside the drain spout. First apply glue on the drain spout and inside the drain end, then secure with one or two collars.

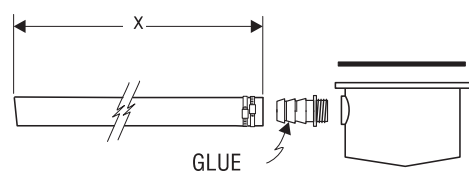

Cut the hose so that it ends with the stone dust (or sand). Measure the pool radius from the center of the drain, then add 15 cm (6").

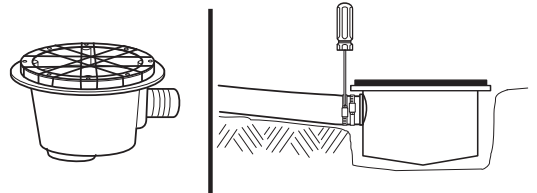

Place the assembled bottom drain in the hole so that it is approximately 1.3cm (1/2") higher than the surface soil. Bury the hose, levelling the drain as much as possible. Compact the soil, using your feet and a tampering tool as well.

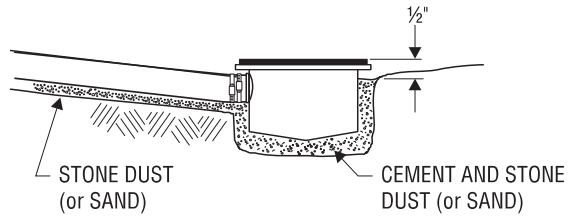

Mix three (3) shovels of stone or sand dust with one half shovel of pure cement, adding a small quantity of water, then pour the cement around the drain until it reaches 1.3 cm (1/2") from the top.

4

BOTTOM WALL TRACKS ASSEMBLY

Insert the wall tracks on each side of the joiner plates, making sure to leave a 1.3 cm (1/2") space between the ends of both tracks, in the center of the joiner plate (See Illustration 4.1).

Make a complete circle, using half of the wall tracks and joiner plates found in the pool kit (See Chart and Illustration 4.2).

Illustration 4.1

Illustration 4.2

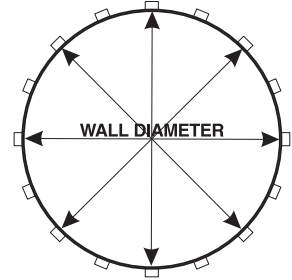
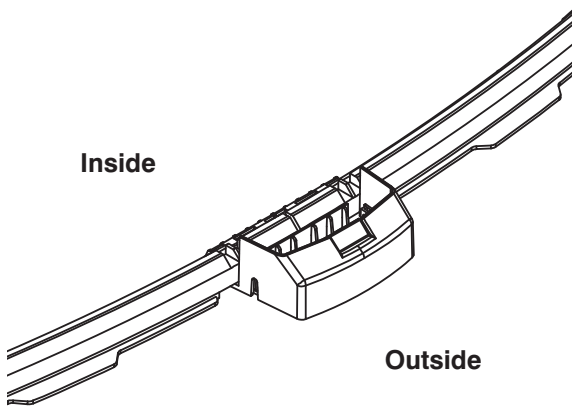

Chart

POOL DIAMETER	NUMBER OF TRACKS	NUMBER OF PLATES
3.66 m (12')	10	10
4.57 m (15')	11	11
5.48 m (18')	13	13
6.40 m (21')	15	15
7.31 m (24')	17	17
8.22 m (27')	19	19
9.14 m (30')	21	21

5

WALL INSTALLATION

Before uncoiling the wall, make sure the pre-punched holes for the skimmer and pump return are at the top and facing the planned location of your filter.

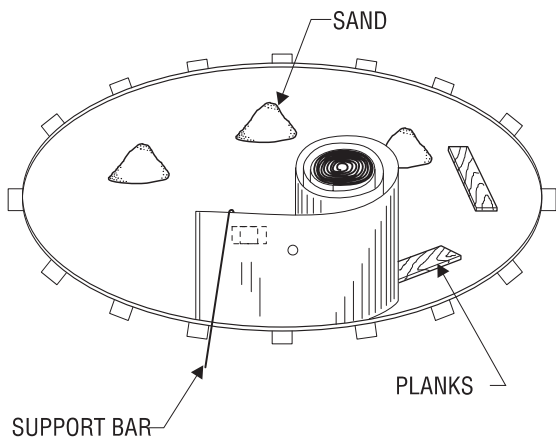
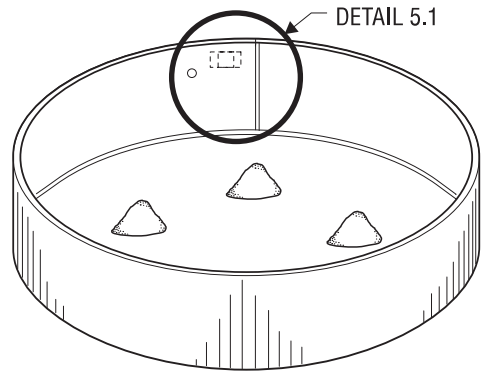

Begin inserting the wall into the bottom wall tracks in the middle of a joiner plate. At first, the wall should be kept in place with one or two support bars (or extra persons).

One person should uncoil the wall on a beam or a plank while a second person inserts it in the bottom wall tracks. Do not uncoil more than 3 m (10') of wall before you install a support bar to reinforce the structure.

Once the wall is completely uncoiled, you may find that it is too long or that both ends do not meet by a few centimetres. If such is the case, you must gently push the wall in or out. If this does not work, roll up the wall again, realign the grooves and uncoil the wall once more. If the spread is too wide, measure the wall and check it against the following chart.

When you prepare to join the ends of the wall, make sure the end that is reinforced by the fold is inside the circle, facing the liner and that the other end faces outward (See Illustration 5.1). When the wall joint is screwed, install the round stabiliser on top of it.

IMPORTANT: Due to the enormous pressure exerted by the water on the steel wall, it is absolutely essential that all the bolts are tighten to a minimum of 60 in-lbs and maximum of 85 in-lbs and no hole is left open. All bolt heads must be inside with nut/washer outside. Cover all bolt heads with heavy fabric tape.

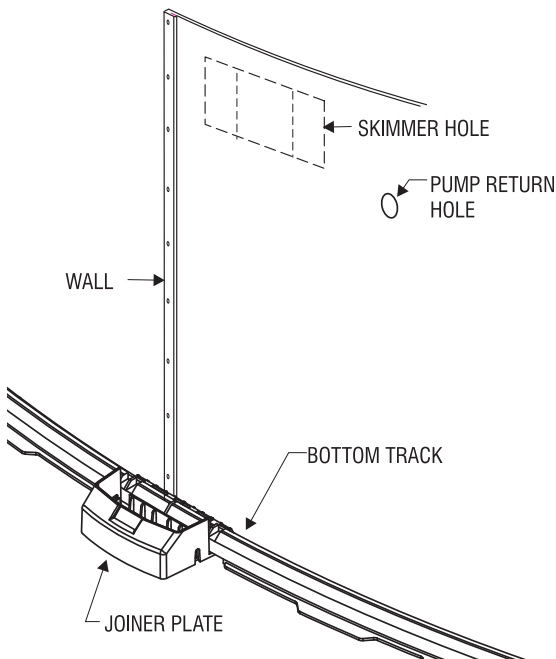
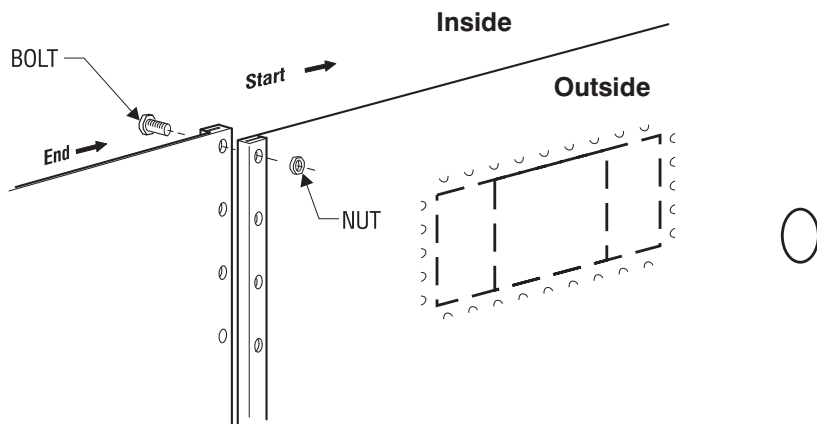

Illustration 5.1



5

WALL INSTALLATION (continued)

Chart

POOL DIAMETER	ACTUAL LENGTH OF WALL
3.66 m (12')	11,52 m (37' 9 3/8")
4.57 m (15')	14,39 m (47' 2 1/2")
5.48 m (18')	17,26 m (56' 7 1/2")
6.40 m (21')	20,31 m (66' 5/8")
7.31 m (24')	23,00 m (75' 5 3/4")
8.22 m (27')	25,88 m (84' 10 7/8")
9.14 m (30')	28,72 m (94' 3")

WARNING

Join the ends of the wall with plies facing outward.

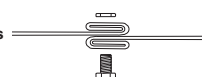

WARNING

Do not use impact gun for wall screws.

Minimum clamping force of 60 inch pounds to maximum of 85 inch pounds



6

SAND BASE FINISHING

You can now spread approximately 10 cm (4") of compacting sand all around the inside base of the wall in order to protect the liner from the cutting edges of the bottom wall tracks and the stone dust (if applicable). Or install a prefabricated cove, if available.

SAND BASE FINISHING

Level finishing sand one last time. Make sure that any sharp stones, debris or roots have been removed from the surface. For better protection, spray sand with water and pack it once more until the base is nicely even.

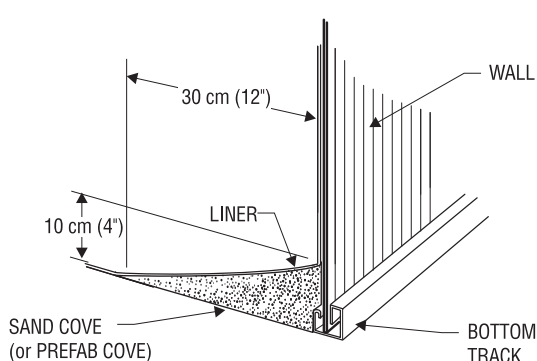

7

VINYL LINER INSTALLATION

Before pulling the liner up against the wall, insert a vacuum cleaner hose down into the pump return hole to approximately 15 cm (6") from the ground.

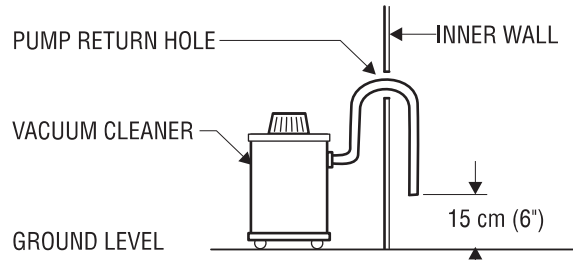

Maintain the hose in place with adhesive tape. Don't forget to block the skimmer hole with adhesive tape to prevent air from leaking in.

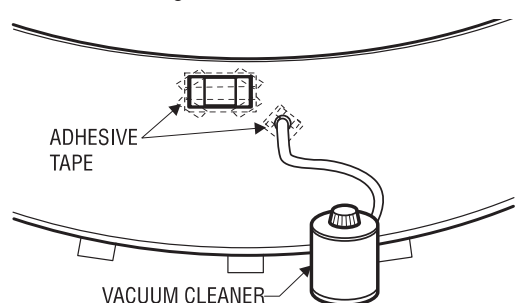

Place the unfolded liner in the center of the pool area at right angles with the skimmer hole. Make sure you wear light, flat-soled shoes to walk on the sand as the slightest heel mark could be visible once the pool is filled.

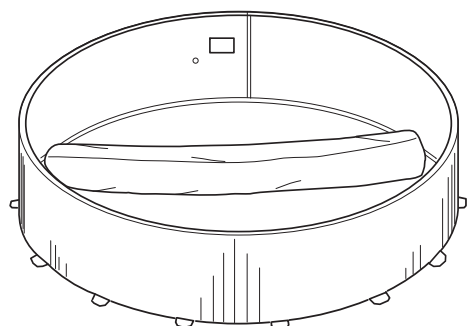

Carefully unfold the liner, bringing the bottom-sidewall seam close to the wall base. Make sure that the side with the protruding seams faces downward or that the patterned side faces upward.

Lift up a section of the liner over the top of the wall leaning a 10 cm to 15 cm (4" to 6") fringe outside the wall. Secure the liner with a plastic coupler.

At this point, the liner may be too tight, making it difficult to drape the overlap or, on the contrary, too loose. In such cases, you will have to redistribute the tension in the liner by removing some of the couplers and readjusting the liner.

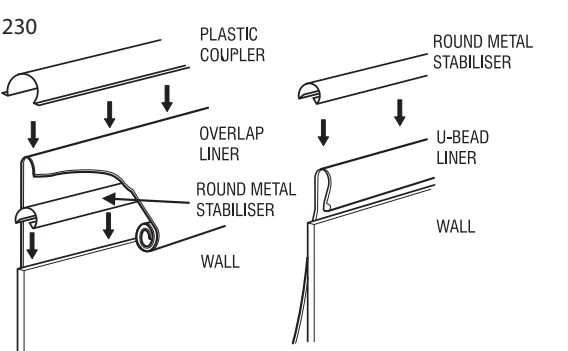
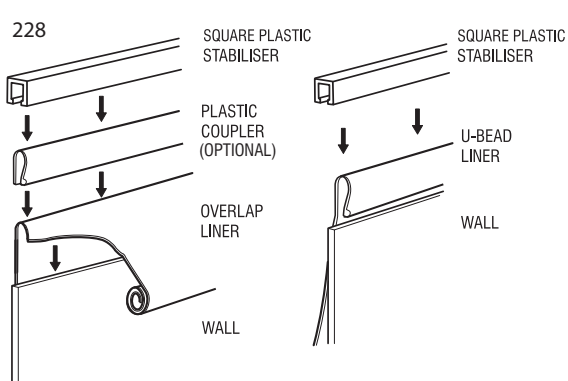

Installation detail of the liner with the square steel track.

Hang the liner on the top of the wall and install the round stabiliser to secure.

Start the vacuum cleaner to allow the liner to adhere to the wall and check for excess tension at the bottom or for wrinkles. Adjust the liner by removing couplers if needed, to lift or lower it in order to ensure a perfect fit.

Fill the pool up to the base of the wall before stopping and removing the vacuum cleaner.

PUMP RETURN FITTING

After you remove the vacuum cleaner, you may install the return fitting. Place the return fitting ring against the liner and adjust it so that it is perfectly aligned with the hole in the wall. When the ring is properly positioned and secured, cut the liner in the middle of the ring.

Insert the return fitting from the inside, placing the first gasket between the return fitting and the liner and the second between the wall and the liner. Then tighten the outside ring with large pliers, taking care not to crease the liner.

BOTTOM DRAIN (optional)

Find the holes through the middle of the liner and screw the ring and gasket in against the liner before cutting the liner in the middle of the ring, then screw on the drain cover.

8

UPRIGHT INSTALLATION

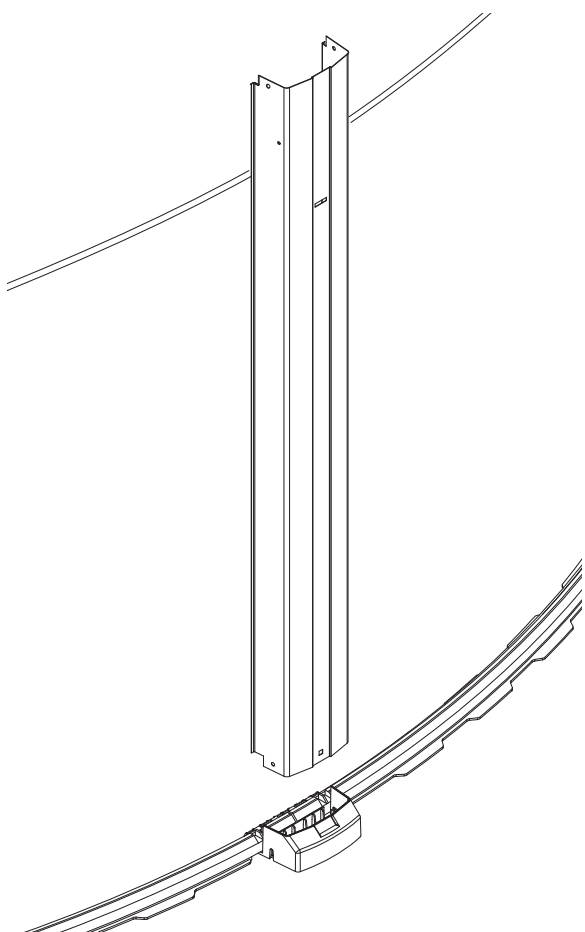

Attach the uprights to the bottom joiner plates with two (2) screws "Z", which you will find them in the hardware bag.

Uprights must be installed inside of the joiner plate and in the two notch of the wall track.

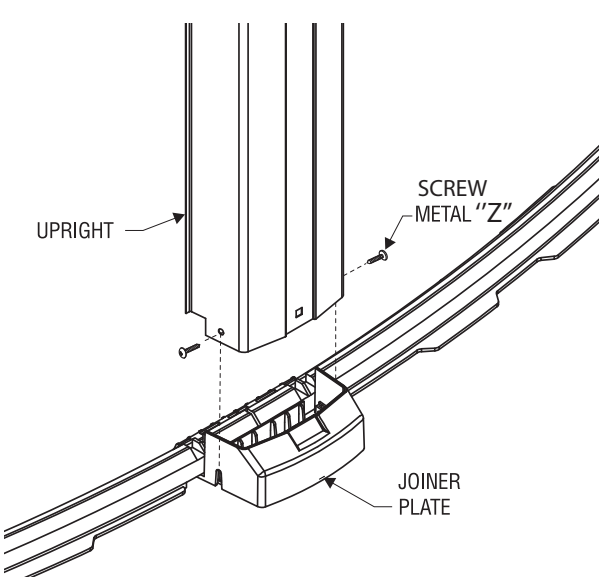

9

JOINER PLATE INSTALLATION

Install the joiner plate on the upper side of the upright, and

secure with two (2) screw "Z" on each side.

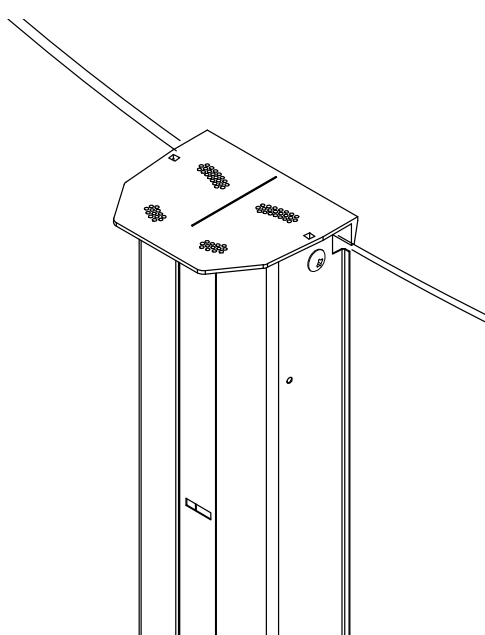
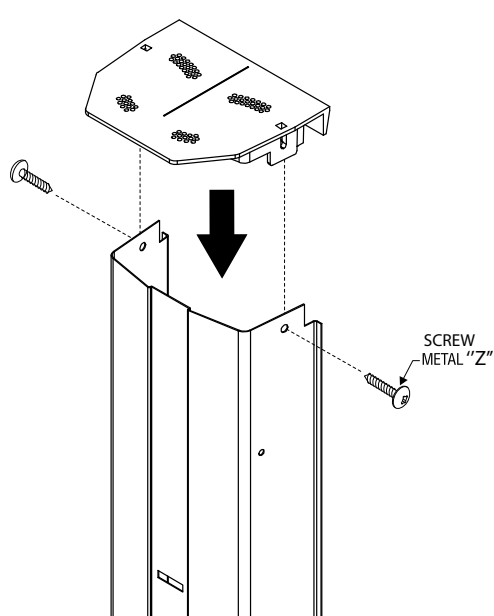

10

TOP SEAT INSTALLATION

Be sure to have a vertical upright before installing the top seat. Place the top seat on the upper side of the upright. Center the top seat between the two uprights and secure with four (4) screw "Z".

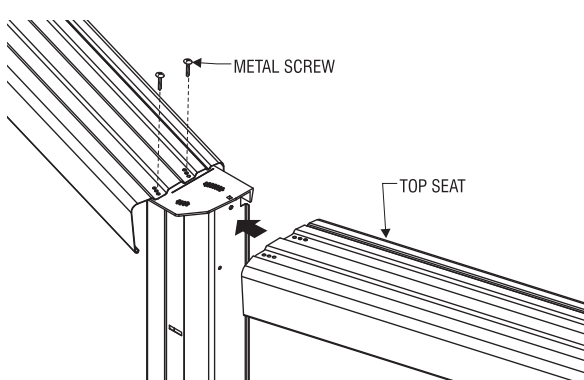

11

SEAT CAP INSTALLATION

Hold the base of the outside lens seat cap in the slot on the front of the upright and upper ledge on the outside edge of the seat. Hold it in place on the upright with two (2) screws on each side. Then place the other part of the seat cap on the inside edge of the seats and snap on the out side seat cap.

Optional lighting: Pass the sensor wire through the hole on top of the seat cap and hold it in place with the plastic frame. Connect the two wires together and replace the battery case in the lens housing. Install all in the seat cap.

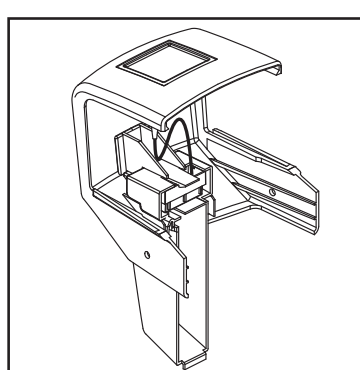
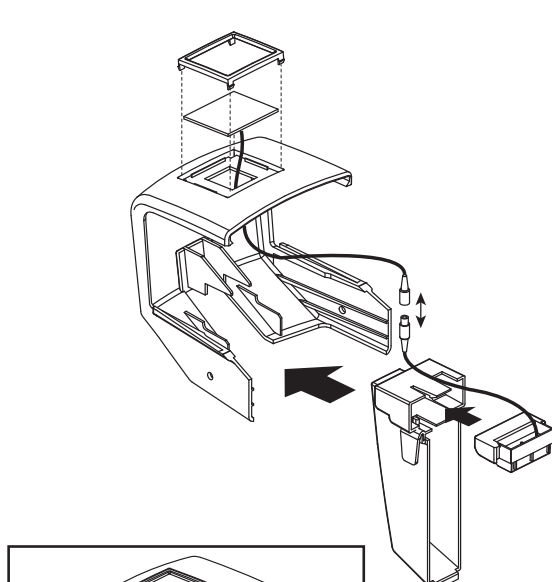
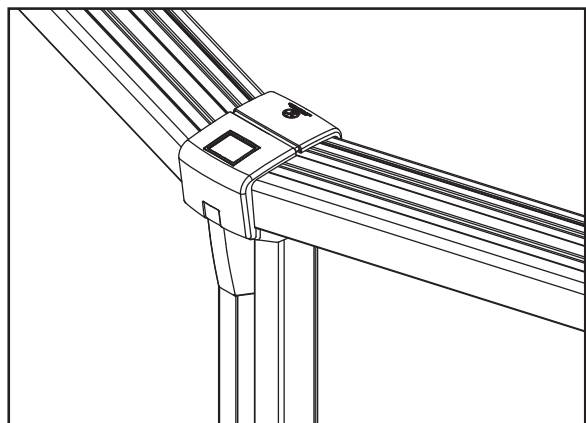
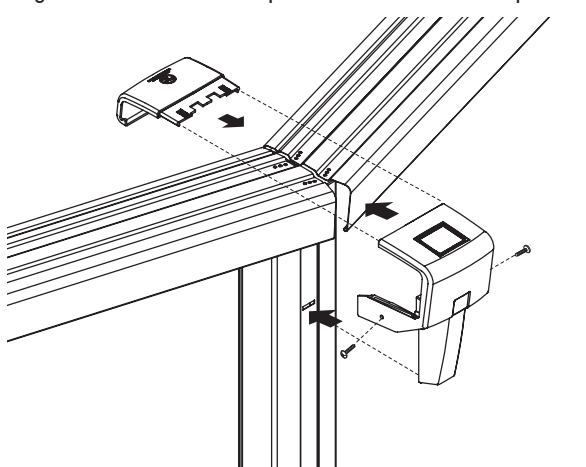

12

SECURITY SIGNS INSTALLATION

Position the safety procedures panel on the outside of the pool. This panel must be at the most visible place from the yard on your pool.

Place the three (3) safety stickers inside the pool in a way that it's seen from any entry point of the swimmer (See positioning drawing).

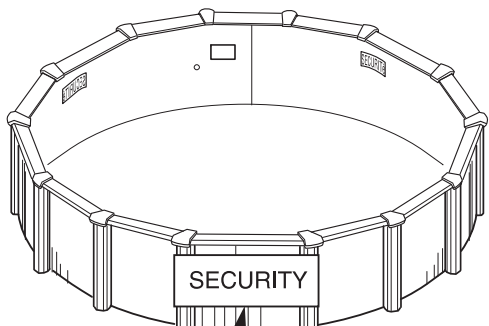

SECURITY sign

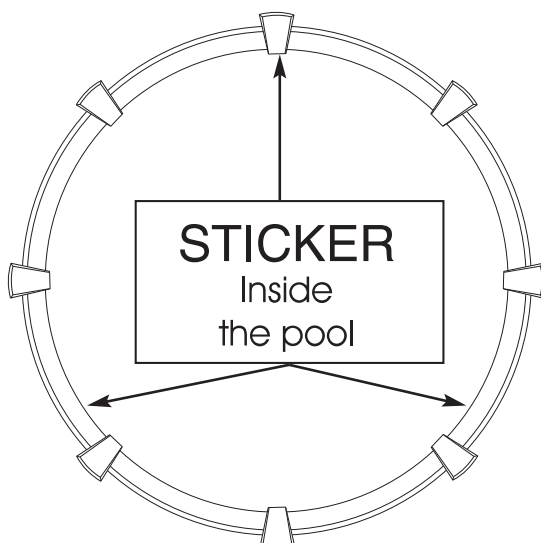

13

FILTRATION SYSTEM ASSEMBLY

Note: See 'Safety Information' Manual, Page 1. As described in the manual, all components of the filtration system should be placed to prevent a child to climb on top and get access to the pool. Filtration system must be install at 1m (40") from the pool wall.

Using a little bit of stone dust (or sand), place at level a patio stone 61 cm x 76 cm (24" x 30") before installing the motor and filter.

Position the motor on the stone and insert the two nozzles to connect the hoses.

Then, install the filter tank. Adjust the lateral assembly properly in its channel. It is sometimes necessary to install the laterals.

Patch the center hole of the lateral assembly using the plug to allow filtering sand to flow into the tank.

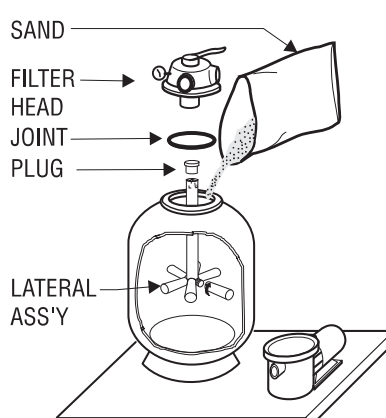

13

FILTRATION SYSTEM ASSEMBLY (next)

Remove the plug. Install the joint in the cavity and secure the filter head by placing the back wash position on opposite side of the pool.

Install necessary nozzles, then connect hoses using collars.

1. The first hose runs from the top of the pump to the side of the filter head;
2. The second one goes from the pump to the skimmer (or to the bottom drain valve);
3. The third goes from the front of the filter head to the water return or from the front of the chlorinator to the water return.

A back wash hose may be placed behind the filter head.

If there is a chlorinator and/or heat pump, it must be assembled at the filter exit.

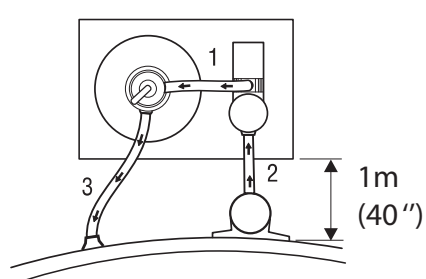
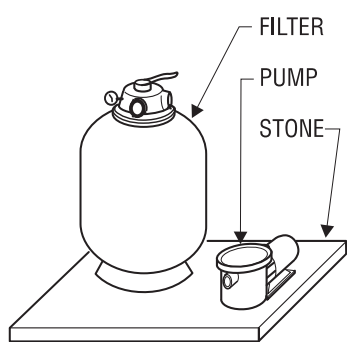

14

DRAIN VALVE ASSEMBLY (if applicable)

Insert threaded nozzles, if applicable, in order to be able to screw the valve in the skimmer.

Connect the drain hose to the bottom nozzle. Connect the motor hose to the side nozzle.

The threads on all threaded nozzles must be covered with teflon tape prior to installing in order to prevent water leaks. Teflon is applied to the threads as follows: little or none on the first few threads (to facilitate introduction) and several layers towards the end threads (for better watertightness).

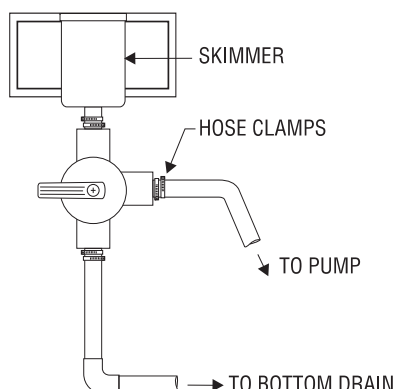

15

PARTS LIST

ARTICLE	DESCRIPTION	12' 3,66 m	15' 4,57 m	18' 5,48 m	21' 6,40 m	24' 7,31 m	27' 8,22 m	30' 9,14 m
A	Top seat	10	11	13	15	17	19	21
B	Upright	10	11	13	15	17	19	21
C	Reinforcement plate	10	11	13	15	17	19	21
D	Seat cap	10	11	13	15	17	19	21
E	Joiner plate	10	11	13	15	17	19	21
F	Wall track	10	11	13	15	17	19	21
G	Round stabiliser	10	11	13	15	17	19	21
H	Plastic coupler	10	11	13	15	17	19	21
J	Wall	37 9 (11,51m)	47 2 (14,39m)	56 7 (17,26m)	66 (20,16m)	75 5 (23,01m)	84 10 (25,88m)	94 3" (28,72m)
L	Bolt - nut (for 52) for wall	" 29	" 29	" 29	" 29	" 29	" 29	29
M	Drain kit (if applicable)	1	1	1	1	1	1	1
N	Screw guard	20	22	26	30	34	38	42
O	Seat cap lens	10	11	13	15	17	19	21
Z	Screw no 14 x 1 in	100	110	130	150	170	190	210

